

## DO NOT REMOVE PRIOR TO SALE!

### OWNER'S MANUAL for Model Nos. 24M11-S22

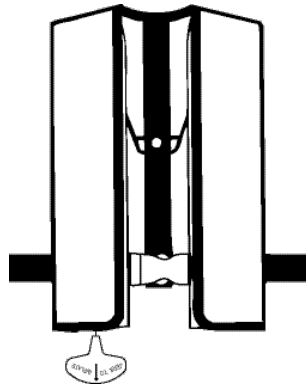

#### APPROVAL CONDITIONS AND CARRIAGE REGULATIONS

These inflatable PFDs are approved by the U.S. Coast Guard for use as Type V Personal Flotation Devices (PFDs), and approved **ONLY WHEN WORN**. They provide Type III performance under approval limitations only if used in accordance with its Owner's Manual. ***It is not approved for water skiing or other high impact, high speed activities.*** This inflatable PFD was designed to be more comfortable and less restrictive to wear than inherently buoyant PFDs. When used and serviced according to this owner's manual, this PFD can greatly increase your chances of survival in the water. Not recommended for non-swimmers or weak swimmers. Users of inflatable PFDs must be at least 16 years old.



### **CONDITIONS FOR THIS TYPE V APPROVAL**

This inflatable PFD is approved for use as a substitute for a Type III PFD **ONLY WHEN WORN**.

Conditional approvals are granted by the Coast Guard for PFDs that:

1. Do not meet all the requirements for approval under the Type I through IV categories but offer other significant safety features, or
2. Have features or uses not found in Type I through IV PFDs that require special user knowledge.

The conditions let the user overcome design traits that would otherwise prevent approval.

#### **“Approved Only When Worn”:**

This PFD has the, “Approved Only When Worn”, condition on its approval because if it is not worn whenever above deck and underway, it is less likely to be in working order and cannot be counted as a PFD to meet the carriage requirements on your boat.

This inflatable PFD requires more frequent checks than ones that are inherently buoyant or have cylinder seal indication. Wearing this PFD will:

1. Provide it the extra attention associated with use,
2. Help you address its disadvantages, and
3. Increase safety enormously because you have it when needed.

Owners of inflatable PFDs must understand the unique characteristics of these products so that they can use them safely.

#### ***You must learn how to properly arm the PFD.***

**Why:** An improperly armed mechanism may not inflate the chamber. This PFD will not float you without being inflated.

*You must check the status of the mechanism and the CO2 cylinder before each outing. If the cylinder cap is punctured there will be no gas to inflate the PFD. Also, if the cylinder is deformed in any way, there may not be gas to inflate the PFD.*

**Why:** This PFD will not float you unless it can be inflated.

**Why:** Are you sure that no one else inflated the PFD recently and did not replace the cylinder?

**Why:** U.S. Coast Guard studies have shown high percentages of unserviceable inflatable PFDs with used cylinders in them when used by recreational boaters.

*In addition to inspecting the mechanism and cylinder before each outing you must periodically check the other components of the PFD. This would include the chamber, webbing, buckles and thread.*

**Why:** The chamber may get punctured, or abraded to the point where it will not stay inflated.

**Why:** Over time these components can wear out and not be strong enough to perform their intended function when needed.

**Please read the entire owner's manual for more details about the use and care of this Inflatable PFD.**

## **SPECIFICATIONS**

**Chest Size:** 30 - 52 inches (76 - 132 cm)

**Weight Range:** More than 80 pounds (36 kg)

**Age Range:** 16 years of age and older

**Buoyancy (minimum):** 22.5 Pounds (100 Newtons) when fully inflated

### ***Inflation System:***

**Manual Inflation Mechanism** (located on your right side)

**Oral Tube** - (located on your left side)

**Pull Tab** - (located on your right side) used to manually activate the inflation mechanism and inflate the PFD.

**CO2 Cylinder:** 24 Gram, 1/2 inch thread

**•• USE REARMING KIT 24MRP ••**

### **DONNING INSTRUCTIONS –**

Practice closing hardware and adjusting before use or prior to in-water testing (Pages 11, 12 and 13).



#### **STEP 1**

Wear like a jacket, inserting arms between straps and fabric.



#### **STEP 2**

Close front buckle, manual pull lanyard should be visible on your lower right side.

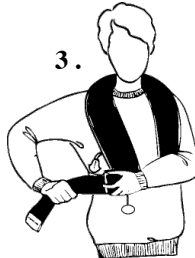

#### **STEP 3**

Adjust **Waist Strap** through slide located on right side until comfortably snug fit is obtained. Tuck free end of belt under waist strap.

### **I. MANDATORY CARRIAGE REQUIREMENTS**

Federal regulations in 33 CFR 175-1993 require you to carry Coast Guard approved personal flotation devices (PFDs) legibly marked with the Coast Guard approval number which are in good and serviceable condition and are the correct size for each person on board. To be considered serviceable, this PFD shall not exhibit deterioration that could diminish its performance such as broken or deformed hardware, detached webbing, rotted structural components, air leaks, or non-functional oral inflation tube. Unless worn inflated, this PFD must also be properly armed with a full CO2 cylinder, inflation system status indicator, and an accessible manual inflation lanyard. A PFD which is "approved only when worn" or "required to be worn" must be worn under the specified conditions.

## II. INSTRUCTIONS FOR USE

### A. PRE-DONNING INSTRUCTIONS

<b>CHECK THE FOLLOWING BEFORE USING THIS PFD:</b>
---

- |   |
|---|
| <ol style="list-style-type: none"><li>1. INSPECT PFD FOR DAMAGE</li><li>2. EXAMINE INFLATION MECHANISM STATUS INDICATORS</li><li>3. EXAMINE CO2 CYLINDER FACE FOR PUNCTURE HOLE</li></ol> |
|---|

<b>READ BELOW FOR MORE DETAILED INFORMATION!</b>
--

#### 1. Inspecting Your PFD For Damage

Make sure that the PFD is free from rips, tears or punctures. This type of damage on the outside covering indicates that the **Inflatable Chamber** may have been exposed to potentially damaging elements. If these defects are noticed, discontinue use of the PFD until you have the PFD inspected by an authorized repair facility. The **Inflatable Chamber** should be checked for leaks at the beginning of each season and at least every two months during the boating season. The leak test procedure is described under **USER'S INSPECTION**. (Refer to Page 10.)

**2. Examine the INFLATION MECHANISM Status Indicators.** The Inflation Mechanism Status Indicators will tell you if the inflation mechanism is properly ARMED/REARMED and ready for use. The status indicator check instructions are provided on the device near the inflation mechanism. **Refer to Page 19 for location of inflation mechanism.** Manual inflator has a single indicator for the Jerk to Inflate Lever.

The color of all **Status Indicators** have standard meaning:

**GREEN = OK = READY**

**RED = NOT READY = SEE REARMING INSTRUCTIONS**  
**(Back Cover)**

All status indicators must be green for the mechanism to be properly reset. **If any indicator is red, immediately REARM.** See Back Cover for instructions.

### **3. Examine Your CO2 Cylinder**

The CO2 cylinder contains the gas charge that will inflate your PFD when you jerk the **pull tab** firmly downward. You must verify that the CO2 Cylinder installed is of the correct size and has not been previously used. To examine the cylinder, you must Unscrew it and visually examine the flat surface on the threaded end (see steps 4 and 5 on Back Cover). There are no indicators to show that the CO2 cylinder is full. The cylinder needs to be replaced if there is any visible damage on the flat surface. See the SPECIFICATIONS section, Page 3, of this manual to determine the proper size cylinder. Proper cylinder size includes both thread size and CO2 gram weight. If the cylinder is OK, you must properly screw it back into the mechanism. If the cylinder is damaged, discard and install a new, undamaged cylinder into the mechanism.

#### **Additional Notes on CO2 Cylinders:**

- a. FAILURE to properly rearm the inflation mechanism prior to installing the *CO2 Cylinder* will result in premature activation of the cylinder.
- b. *CO2 Cylinders* are only good for **one** inflation and cannot be recharged.
- c. *CO2 Cylinders* are made with a protective coating that may wear off after a period of use or exposure to the environment. When this coating is worn off, the *CO2 Cylinder* may start to show some signs of rusting. If this occurs, replace the *CO2 Cylinder*.
- d. If a gram scale (such as a postal scale) is available, it is recommended to weigh the cylinder to verify that it meets the minimum weight imprinted on the cylinder.

### **B. REARMING AND INDICATOR CHECK INSTRUCTIONS**

The back cover of this manual provides the REARMING and INDICATOR CHECK INSTRUCTIONS for the mechanism on your PFD.

### C. DONNING INSTRUCTIONS

See Page 4 for pictogram instruction. After donning, locate the **Jerk to Inflate** tab for the mechanism. It should protrude from the PFD as shown on the pictogram. Make sure that you are comfortable locating the **Jerk to Inflate** tab with either hand. Should an emergency develop, be prepared to use it! Always wear your PFD over, not under clothing. Caution - Bulky clothing may affect the ability of this PFD to turn the wearer to a face-up position in the water.

### D. INFLATED DONNING INSTRUCTIONS

Inflatable PFDs can be very difficult to don when fully inflated. Deflate through the Oral Tube until enough gas has escaped to don. See DEFLATION INSTRUCTIONS on Page 8. Don as described above and re-inflate orally as described below.

### E. INFLATION INSTRUCTIONS

1. **MANUAL INFLATION** - To inflate, grasp the **Jerk to Inflate** tab and pull sharply downwards.
2. **ORAL INFLATION** - The **Oral Tube** is located on the wearer's left side. Grasp the **Oral Tube** and bring to mouth. Blow air through the **Oral Tube** until the **Inflatable Chamber** is firm. **If the chamber becomes soft due to CO2 permeance** (normal loss of cylinder gas over extended period of time), **Oral Inflation will be necessary to maintain full buoyancy.**
3. **COLD INFLATION** - Oral Inflation may be required in addition to manual inflation if chamber is not firm due to cold temperatures at or below 40° F (4°C). Inflation Time using CO2 gas will be longer at these temperatures.  
**See FREEZING TEMPERATURES on page 9.**
4. **OTHER INFLATION INSTRUCTIONS**
  - a. CAUTION - Do not fully inflate orally then manually inflate with the CO2 cylinder. Repeated CO2 inflation after oral inflation will damage the PFD to the point that it will not hold air or float.
  - b. Never inflate this PFD with a Pump or Air-Compressor.
  - c. Permeation loss is greater when the device is inflated with CO2 than with air, and that earlier replenishment by means of the oral inflation system will therefore be necessary.

## F. DEFLATION INSTRUCTIONS

Depress **Oral Valve** (located inside end of **Oral Tube**) using the protective cap or tab provided by inserting into the end of **Oral Tube**, see drawing. Gently compress air out of the inflatable chamber while depressing the **Oral Valve**.

**DO NOT TWIST OR WRING INFLATABLE CHAMBER TO DEFLATE.**

If for any reason the Oral Valve remains open, depress it several times. If it does not release, discontinue use of this PFD and take it to a certified Stearns Repair Facility. In an emergency situation, hold thumb over the valve if it will not close.

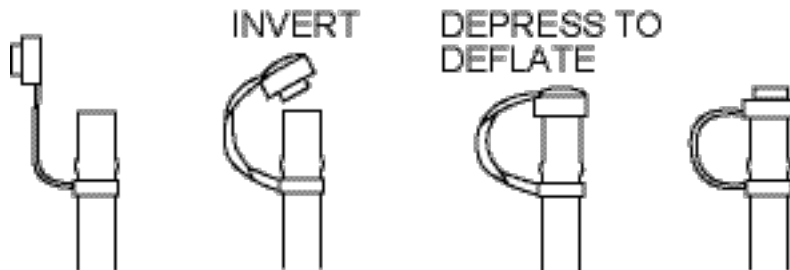

**Refer to the back inside cover for REPACKING INSTRUCTIONS.**

## G. OTHER USE GUIDELINES

1. Always wear your PFD when underway unless you are inside a cabin.
2. If you need to jump from any height always fold arms over your chest to keep the PFD in place when entering the water.
3. Avoid all unnecessary activities that will be abrasive to the device.
4. Use extreme caution around sharp objects.
5. Avoid unnecessary exposure to the sunlight. See GENERAL PRODUCT LIFE EXPECTANCY on page 9.
6. Inflatable PFDs are not designed for activities in which the wearer expects to encounter impact with the water at a high-speed such as water skiing, riding personal water-craft; etc.



7. Never use in below **freezing temperatures** unless worn partly inflated. At or below 40°F inflation time with CO2 gas will be longer. Wearing a partially inflated PFD under these conditions will provide some initial buoyancy while the PFD fully inflates.

Caution: Do not fully inflate orally and then inflate with the CO2 cylinder. Repeated CO2 inflation after oral inflation will damage the PFD to the point that it will not hold air or float.

### **III. CARE AND MAINTENANCE INSTRUCTIONS**

#### **A. GENERAL PRODUCT LIFE EXPECTANCY**

The reliability and service life of this PFD depends greatly upon how it is used and cared for. Avoid storing PFD in direct sunlight. Sunlight contains ultraviolet radiation that weakens synthetic materials. Prolonged exposures to high temperatures and high humidity may shorten service life of this PFD. While it is known that these elements degrade the materials, every use environment is unique so there is no sure way to estimate how long the PFD will last. It is for this reason that you must follow the Care and Cleaning Instructions and perform the maintenance and service checks. This will assure that the PFD remains functional and will maximize the useful life of this PFD. Failure to follow these instructions rigorously could result in a non-functioning PFD causing **injury or death**.

#### **B. CARE AND CLEANING INSTRUCTIONS**

**Drying** - If the device is wet, place on a coat hanger to allow thorough drying. Do not place in direct sunlight to dry. Do not use any heat source or place on radiator.

**Cleaning** - Damp wipe only with mild detergent recommended for synthetic fabrics. Remove grease and oil immediately. Always rinse well with fresh water. Read instructions provided on the device.

- DO NOT MACHINE WASH
- DO NOT MACHINE DRY
- DO NOT DRY CLEAN
- DO NOT USE SOLVENT BASED CLEANERS
- DO NOT BLEACH

## C. INSPECTION

**Certified Inspection** - Stearns strongly recommends that this device be inspected at least every 24 months by a certified Stearns Repair Facility or STEARNS Inc.

**User's Inspection** - The users should perform the following checks before each season, or before a long journey, or as recommended below:

- 1. Leak Test** - This test should be performed every two months and at the start of each season. (a) Remove the CO2 cylinder (b) Inflate using the oral inflator (c) Leave to rest for 16 hours. If buoyancy chamber remains firm and full of air, there is no leakage and chamber is in operational condition. If the chamber deflates, immediately bring to a certified Stearns Repair Facility for repair. The device is no longer in operational condition. (d) Deflate, install the CO2 cylinder, inspect to ensure that the PFD is properly armed (Back Cover) and then repack the PFD (page 19) so it's ready for use.
- 2. Function Test of Oral Valve** - Remove the dust protection cap. With the PFD inflated (see steps a and b of Leak Test, (above), test the valve by pushing it down using the tab provided on the cap (refer to page 8). The valve should depress easily. When released it should automatically return to the closed, resealed position. Prepare the PFD for use (see step d of Leak Test).
- 3. Physical Inspection of Cover and Straps** - Examine outer shell fabric, seams, webbing attachments, buckles, slides; etc. Fabric fading can indicate a loss of strength. Check for strength by pulling seams and attachments snugly. If device shows any signs of damage, return to a certified Stearns Repair Facility or replace the entire device. This inspection should be performed each outing.

## D. STORAGE

- STORE IN CLEAN, COOL, DRY AREA.
- DO NOT STORE IN DIRECT SUNLIGHT.

## IV. IS YOUR PFD IN GOOD AND SERVICEABLE CONDITION?

Check your PFD between outings to be sure that it is properly armed; that it is free of rips, tears or holes; that all seams are securely sewn; and that the fabric, straps and hardware are still strong. Inspect the inflatable portion of the PFD in accordance with Care and Maintenance Instructions on page 9.

## V. WHY ARE PFDs REQUIRED SAFETY EQUIPMENT?

Drownings are the leading cause of fatalities involving recreational boating. A PFD provides flotation to help keep your head above water, help you to stay face up in the water, and increase your chances for survival and rescue. Most adults only need an extra 7 to 12 pounds of flotation to keep their heads above water. The proper size PFD will properly support the weight of the wearer.

Since this inflatable PFD does not have inherent buoyancy, it provides flotation only when inflated. Familiarize yourself with the use of this PFD so you know what to do in an emergency.

## VI. HOW AND WHY TO TEST YOUR PFD?

Inflate your PFD and try it out in the water to:

- Make sure it floats you:  
*Comfortably*  
(When worn properly)  
*Adequately for expected wave conditions*  
(Body shapes/densities affect performance)
- Make sure it works:  
*A flow of bubbles should not appear*  
(See page 10 for leak tests)  
*It should inflate quickly and easily*
- Learn how it works by:  
*Activating the CO2 inflation system*  
*Rearming the CO2 inflation system*  
*Using the Oral inflator tube*

The U.S. Coast Guard recommends that you purchase two rearming kits. One to be used immediately in testing the inflation system and the other to carry onboard as a spare.

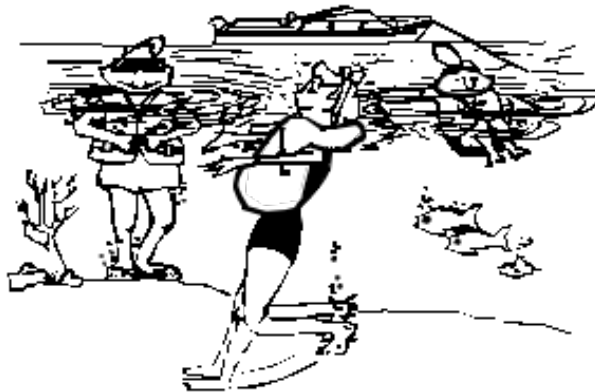

## HOW DO YOU TEST YOUR PFD USING THE MANUAL INFLATOR?

1. To test your inflatable PFD, you will need:
  - Your **fully armed PFD**, and
  - **Rearming kit** approved for your PFD.
2. Put on the PFD.
3. Actuate the inflation system by jerking firmly downward on the pull tab. The PFD should fully inflate within 5 seconds.
4. Get into shallow water, just deep enough that you can stand with your head above the surface.
5. See if the PFD will float you on your back or just slightly back of vertical. In a relaxed floating position, verify that your mouth is well above the water's surface. Note the effect of where you hold your legs on how you float.
6. Get out of the water and remove the PFD. Remove the used CO2 cylinder from the PFD inflator. Completely deflate the PFD using the oral inflator.
7. Let the PFD dry thoroughly. **REARM** and **REPACK** the PFD in accordance with the manufacturer's instructions!

## HOW DO YOU TEST YOUR PFD USING THE ORAL INFLATOR?

1. To test your inflatable PFD, you will **not need any spare parts or rearming kits**.
2. Remove the CO2 cylinder, to prevent inadvertent activation of the manual inflation system which could potentially damage the PFD. Inspect the threaded end to confirm its un-used.
3. Put on the PFD.
4. Get into shallow water, just deep enough that you can stand with your head above the surface.
5. If you are a weak swimmer or non-swimmer, inflate the PFD partially so that you are supported well enough to be able to complete inflation without touching bottom, either orally or manually. Note this level of inflation because it is the minimum needed for you to safely use this inflatable PFD.
6. Fully inflate the PFD using the oral inflator. Place PFD over your head.
7. See if the PFD will float you on your back or just slightly back of vertical. In a relaxed floating position, verify that your mouth is well above the water's surface. Note the effect of where you hold your legs on how you float.
8. Get out of the water and remove the PFD. Completely deflate the PFD using the oral inflator.
9. Let the PFD dry thoroughly. **REARM** and **REPACK** the PFD in accordance with the manufacturer's instructions!

## VII. WEAR YOUR PFD

In approximately 80 percent of all boating fatalities, the victims were not wearing a PFD. Most fatal accidents happen on calm sunny days. This inflatable PFD is much more comfortable to wear than other PFD types. Get into the habit of wearing this PFD. Non-swimmers and children especially should wear a hybrid or non-inflatable PFD at all times when on or near the water.

## VIII. HYPOTHERMIA

Prolonged exposure to cold water causes a condition known as hypothermia - a substantial loss of body heat, which leads to exhaustion and unconsciousness. Most drowning victims first suffer from hypothermia. The following chart shows the effects of hypothermia:

HOW HYPOTHERMIA AFFECTS MOST ADULTS		
Water Temperature °C (°F)	Exhaustion or Unconsciousness	Expected Time Of Survival
0.3 (32.5)	UNDER 15 MIN	UNDER 15 TO 45 MIN
0.3 TO 4 (32.5 TO 40)	15 TO 30 MIN	30 TO 90 MIN
4 TO 10 (40 TO 50)	30 TO 60 MIN	1 TO 3 HOURS
10 TO 16 (50 TO 60)	1 TO 2 HOURS	1 TO 6 HOURS
16 TO 21 (60 TO 70)	2 TO 7 HOURS	2 TO 40 HOURS
21 TO 27 (70 TO 80)	2 TO 12 HOURS	3 HOURS TO INDEFINITE
Over 27 (Over 80)	INDEFINITE	INDEFINITE

PFDs can increase survival time because they allow you to float without using energy treading water and because of their insulating properties. Naturally, the warmer the water, the less insulation you will require. When operating in cold waters [below 60° F(15.6° C)] you should consider using a coat or jacket style PFD or a Type V Thermal Protective PFD as they cover more of the body than the vest or belt style PFDs.

### **Some Points to Remember About Hypothermia Protection:**

1) Always wear your PFD. Even if you become incapacitated due to hypothermia, the PFD will keep you afloat and greatly improve your chances of rescue.

2) Do not attempt to swim unless it is to reach a nearby craft, fellow survivor, or a floating object on which you can lean or climb. Swimming increases the rate of body heat loss. In cold water, drown-proofing methods that require putting your head in the water are not recommended. Keep your head out of the water. This will greatly lessen heat loss and increase your survival time.

3) Use the standard H.E.L.P. position when wearing an inflatable PFD, drawing the legs up to a seated position, because doing so will help you conserve body heat.

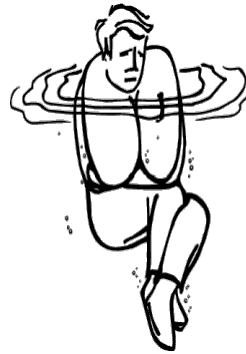

4) Keep a positive attitude about your survival and rescue. This will improve your chances of extending your survival time until rescued. Your will-to-live does make a difference!

5) If there is more than one person in the water, huddling is recommended while waiting to be rescued. This action tends to reduce the rate of heat loss and thus increase the survival time.

## **IX. EACH OF THESE DEVICES IS INTENDED TO HELP YOU SAVE YOUR OWN LIFE**

For your PFD to function properly, follow these suggestions to verify that it fits, floats, and remains in good condition.

- 1) Check the inflation mechanism status indicators before each use.
- 2) Get in the habit of rearming the inflation mechanism right after each inflation.
- 3) Try your wearable PFD on and adjust it until it fits comfortably in and out of the water.
- 4) Mark your PFD with your name if you are the only wearer.
- 5) Do not alter your PFD. If it doesn't fit properly, get one that does. An altered device is no longer Coast Guard approved.
- 6) Your PFD is not intended for use as a fender or kneeling pad.
- 7) If your PFD is wet, allow it to dry thoroughly before storing it. Store it in a well-ventilated area.
- 8) Do not dry your PFD in front of a radiator or other source of direct heat.



## **X. ADDITIONAL INFORMATION**

If you need more information about PFDs and safe recreational boating, contact your state boating authority, U.S. Coast Guard Auxiliary, U.S. Power Squadron, Red Cross, or your nearest unit of the U.S. Coast Guard; or call the CG Customer InfoLine at 1-800-368-5647 or the Free Boating Course number 1-800-336-BOAT (in VA, 1-800-245-BOAT) or see USCG Boating Web Page at [www.boating.org](http://www.boating.org).

### **DO NOT ATTACH PFD'S TO YOUR BOAT**

Each PFD has straps, hooks, buckles, or other means for securing the device in place on the wearer. Some PFDs also incorporate decorative dee rings or tabs. Such items are not to be used to attach the device to the boat. Attaching the device to the boat will not permit it to perform as intended.

### **BUDDY LINE INFORMATION**

Buddy lines, *when provided*, are to be used by people adrift in the water, to attach themselves to one another and aid in staying together. **Buddy lines are not designed for lifting.**

**IF YOU HAVE ANY QUESTIONS ABOUT THE INITIAL ARMING, REARMING, REPACKING, OR NEAREST CERTIFIED STEARNS REPAIR FACILITY CALL 1-800-STEARN'S (1-800-783-2767).**

**PRODUCT REGISTRATION: PLEASE MAIL REGISTRATION CARD OR CALL 1-800-STEARN'S (1-800-783-2767) IN ORDER TO RECEIVE IMPORTANT UPDATES ON THIS PRODUCT.**

**NOTES**

**REPACKING INSTRUCTIONS** - Always *deflate* the PFD and *rearm* the *Inflation Mechanism* - follow REARMING Instructions prior to REPACKING!

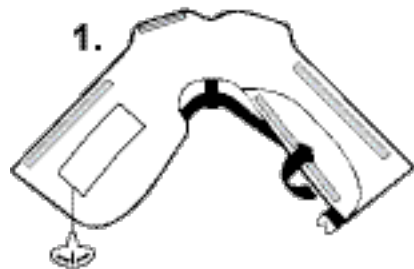

**STEP 1 -**

Lay device out flat with the yellow *Inflatable Chamber* up.

Fold right inside edge over as shown, exposing *Velcro® Strip*.

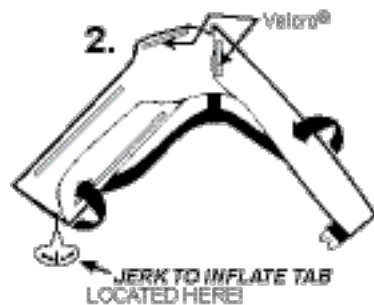

**STEP 2 -**

Fold right outside edge over, securing *Velcro® Strips*.

Position *Jerk to Inflate Tab* below bottom edge of PFD, as shown.

Fold left inside edge over, exposing *Velcro® Strip*.

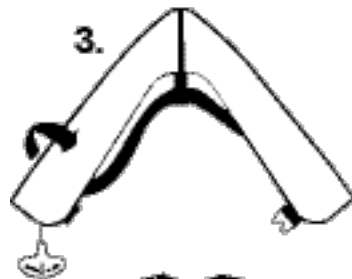

**STEP 3 -**

Fold left outside edge over, securing *Velcro® Strips*.

Fold right topside over, exposing *Velcro® Strips*.

Fold left topside over securing *Velcro® Strips*.

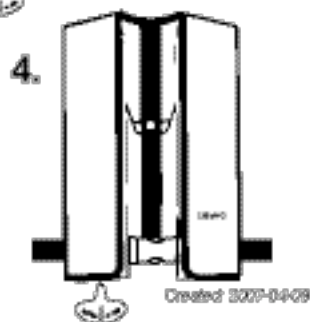

**STEP 4 -**

Snap back strap to shell.

**Secure *Velcro® Strap Extensions*** on models w/o a harness. Examine *all straps, Belt Keepers, Adjustment Slides* and *Buckles* to assure that they are free from twists.

Check to see that the *Jerk to Inflate tab* is hanging free!

**HALKEY-ROBERTS  
840 INFLATOR**

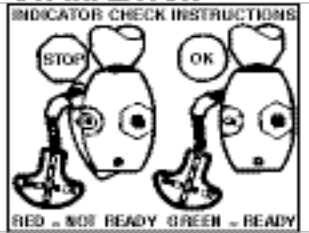

**REARMING INSTRUCTIONS**

**Step 1 Unscrew** used CO<sub>2</sub> cylinder in a **counter-clockwise** direction and immediately **discard**. **Do not insert** new cylinder at this time.

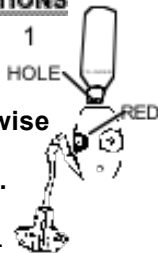

To avoid confusion later in the rearming process, we suggest you throw away the old CO<sub>2</sub> cylinder now.

**Step 2 Close** manual inflator arm within inflator body and carefully **insert** a new **green** indicator **tab** so that it fully **covers** the **red semi-circle** on the body.



**Step 3 Look** into threaded cylinder receiver and view the gasket. If worn, contact Stearns Inc. (1-800-STEARNs) for the nearest certified Stearns Repair Facility.



**Step 4 Inspect** the face of the new cylinder. Be sure it is **smooth** and has no holes or **scratches**.

There is a gross weight on the cylinder. If you have any questions about cylinder integrity, weigh the cylinder on a small scale, such as a postage scale. **Compare** the **weight** printed on the **cylinder** to the **actual weight**. If they **do not match**, get **another** cylinder.



**Step 5 Screw** new cylinder in a clockwise direction firmly into the inflator. Do not over-tighten, but ensure the fit is tight.

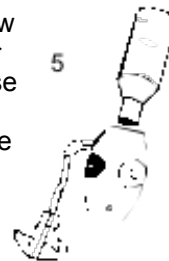

**Step 6 Check** the inflator **arming** indicator **every boating trip**.

The indicator and cylinder tightness tell you if there is a need for service. **Check** the **cylinder face regularly** to ensure it is not punctured. Be sure cylinder is screwed in tight.



**CRP 08-07  
002-BO-158**